

Development of Lightweight – Control Rod made of Fibre Composite Material for Aviation

Martin Welsch & Ralph Funck
CirComp GmbH
Marie-Curie-Str.11
67661 Kaiserslautern, Germany
www.circomp.de

Abstract— This publication deals with the development of control rods for small aircraft and business jets. The load transmission of the developed struts is realized via a conservatively designed form-fitting connection. Due to the chosen design the weight saving compared to conventional aluminium rods is approx. 40%. The load requirements of the control rods could be verified by appropriate tests.

Keywords— Composite material, Control-Rod, Titan, FilaWin®, Aviation, BVID

I. INTRODUCTION

The aviation industry demands increasing stiffness, strength, weight saving and corrosion resistance. In addition to these aspects cost-effectiveness plays an important role. Thus the aim is to develop components with improved or equal properties at lower weight and, if possible, lower costs. In order to meet these challenges it is essential to develop components made of new, lighter materials such as fibre composites.

Control rods made of steel or aluminium are used in aircraft for the flight control system [1]. For example, control rods are used to control the ailerons, rudder, tailplane, etc. (see Fig. 1).

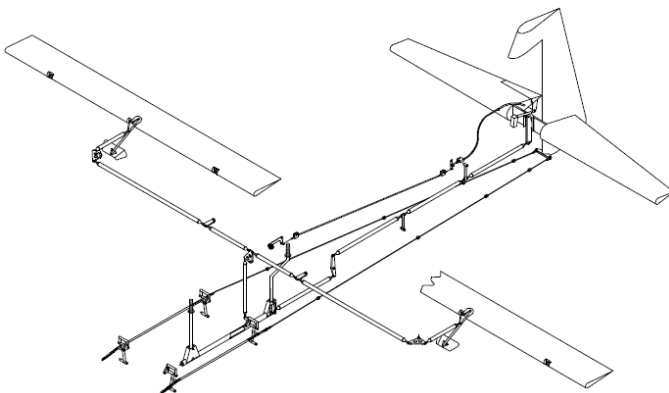

Fig. 1: Example of a flight control system [2]

As part of the development, a design for control rods made of fibre composite is developed and verified.

II. STATE OF THE ART

Control rods usually consist of a tubular body and two rod ends which are adjustable in length. It transmits the axial forces and the axial control movement. Fig. 2 shows the schematic design of a control rod.

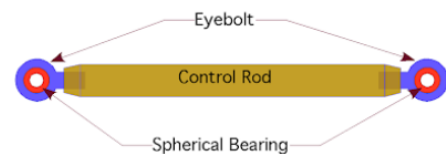

Fig. 2: Schematic design of a control rod [3]

According to the current state of the art these struts are made of steel or aluminium. In order to continue exploiting the potential for lightweight construction there are already developments made of CFRP (see [4]).

III. CONTROL-ROD REQUIREMENTS AND DESIGN

The following requirements are placed on the composite Control-Rod to be developed:

- Ultimate load tension and compression 8kN
- Length eye to eye 990mm
- Maximum outer diameter 28.60mm

For reliable load transmission a form-fit bolt connection is selected between the CFRP tube body and the insert for the load introduction. The dimensioning is carried out in accordance with [5]. The insert has an appropriate thread for the rod end and is connected to the fibre composite tube via titanium pins. For example the insert can be made of titanium or aluminium (with appropriate surface coating). The form-fit connection can be combined with an additional substance-fit connection. No additional bonding is used for the prototype tests.

The CFRP tube body is manufactured by FilaWin® technology. Fig. 3 shows the developed Control-Rod with insert, rod end and locking device.



Fig. 3: AirStrut® CFRP Control-Rod

IV. TESTS

The control rods are subjected to impact tests and subsequent static tensile and compression tests.

1. Impact tests

The impact tests are carried out using a drop tower. A spherical impactor with a diameter of 16mm is used. To determine the BVID (Barely Visible Impact Damage) limit energy, tests are carried out on a CFRP tube body with the same layer structure as the control rods.

The control rods are impacted in the middle of the component.

2. Tension and compression tests

A tensile/compression testing machine is used for the tests. In the first attempt a non-impacted control rod is tested according to the following test procedure:

1. Applying a compression load of up to 8.2kN (travel-controlled at 5mm/min). Hold the load for 2s (force-controlled)
2. Unload
3. Applying a tension load until fracture (travel-controlled at 5mm/min)

In the second test the maximum buckling load is determined. For this purpose a rod is loaded with 5mm/min up to the buckling point.

To check the compression load requirement two impacted rods are subjected to a compression test up to 8.2kN (with 5mm/min).

V. TEST RESULTS

1. Impact tests

To determine the BVID limit energy a tube specimen is impacted with different energies. It starts with an energy of 2J. This is gradually increased until a BVID is present on the tube body. Fig. 4 shows the damage pattern at energies 2J, 3.84J and 5J as an example.

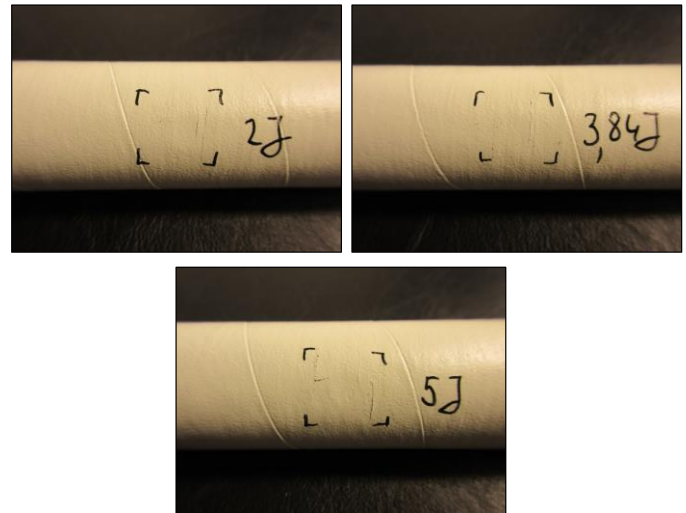

Fig. 4: Results of the impact tests at 2J, 3.84J and 5J

Based on the damage patterns a BVID energy of 5J is defined for the control rods.

2. Tension and compression tests

The test of a non-impacted rod results in the following force-displacement diagram (see Fig. 5).

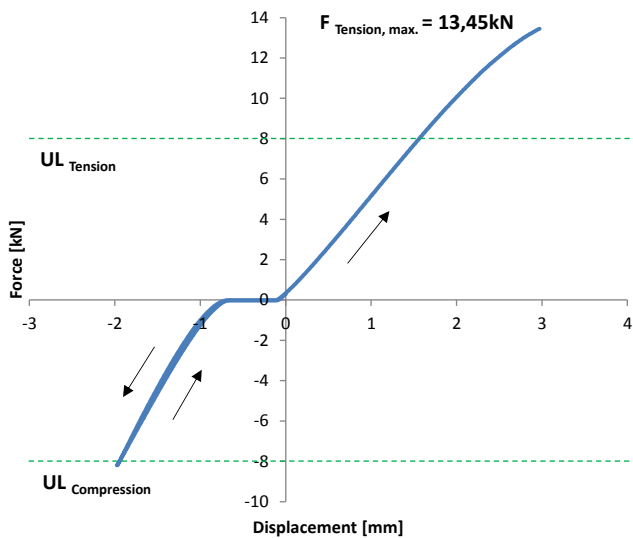

Fig. 5: Force-displacement diagram of a non-impacted control rod

The compression test up to 8.2kN is realized without instability behaviour. At a tensile force of 13.45kN the tensile failure occurs.

In a further compression test of a non-impacted rod a maximum buckling load of 9.1kN is determined.

Fig. 6 shows the result of the pressure test (up to 8.2kN) of a rod impacted with 5J.

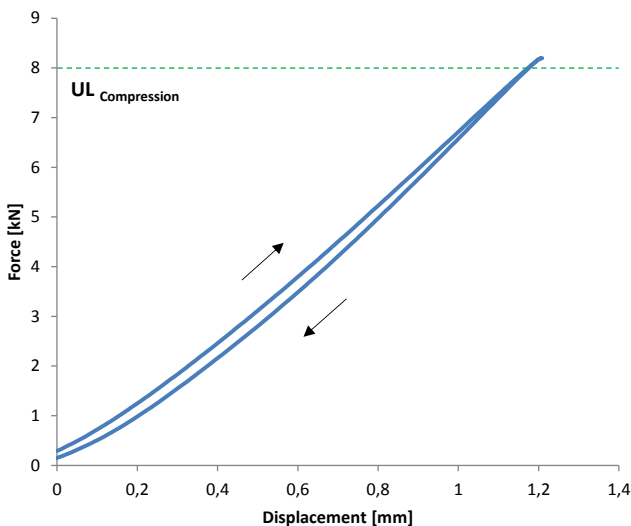

Fig. 6: Force-displacement diagram of an impacted control rod (5J rod centre)

The impact position is in the middle of the rod. No instability behaviour is detected during the test procedure. As a result the developed control rod meets the component requirements. Compared to an aluminium strut the weight advantage is in the range of approx. 40%.

VI. CONCLUSION

As part of the "Control-Rod" development a control rod for small aircraft is designed. A safe, slim and lightweight design is realized. The load is introduced by means of a conservatively designed bolt connection. The AirStrut® Control-Rod prototypes manufactured by FilaWin® technology are subjected to impact tests in order to test the UL (Ultimate Load) load case. The impact tests show that an energy of approx. 5J is required for a BVID in the middle area of the rod.

The tensile and compression tests show that the manufactured prototypes successfully meet the requirements and that the FilaWin® composite control rods can be implemented using the presented design for aerospace applications with the highest demands on quality, safety, weight and load requirements.

REFERENCES

- [1] N. Daneshjo, C.D. Stratyński, A. Kohla, C. Dietrich – Flight Control Systems; Technische Universität Košice; 2013
- [2] Service Manual EXTRA 300; EXTRA Flugzeugbau GmbH; Juni 1996
- [3] W. Stout – Aerospace Flight Control Systems; Design Aerospace LLC; 2018
- [4] J. Ludick, T. Raman – Industrialization of a Carbon Composite Control Rod; 1999
- [5] H. Schürmann – Konstruieren mit Faser-Kunststoff-Verbunden; Springer-Verlag; 2007